

PLC sensors with digital output



digital UV sensor PLC.D

The PLC.D sensors are ready-to-install UV sensors with digital output. This enables reliable and repeatable irradiance measurements in UV systems. Due to the compact design and the eight spectral ranges, the sensors can be used for a wide range of applications, e.g. in

- packaging facilities
- sterilisation
- surface activation systems
- UV curing systems
- ageing tests
- and many other applications

With the integrated 24-bit ADCs, the PLC.D sensors close the gap between industrial manufacturing and high-precision laboratory equipment. Measurements can be carried out in a simple yet safe way. RS-485 and USB are available as optional connections for this purpose. The data evaluation takes place directly in the PLC.D sensors, the measured values are protected against transmission errors by a CRC-16 check sums. The PLC.D sensors also contain all the information required for complete ISO 17025 or manufacturers calibration.

Various functions such as software triggering, hardware triggering or continuous data transmission can be para-

meterised via plain text commands.

Example commands:

• DS_MeasResult?	Request measurement result
• DS_SerialNr?	Request serial number
• DS_Firmware?	Request firmware version
• DS_MeasAVG?!	Request /Set Averaging
• DS_CalibDate?:	Request calibration date
• DS_StartMeas!	Command start measurement
• DS_DataMode?	Request the measuring mode: Software polling, hardware trigger or continuous

The sensors with RS-485 / RS-232 connection operate with an operating and signal voltage of 24 V and contain a trigger input and data ready output. The sensors with USB connection require no external power supply.

HIGHLIGHTS

- Plain text ASCII communication with check sum
- Direct operation at SPS
- Long-term stable and recalibratable
- Eight spectral ranges
- Three measurement modes

TECHNICAL DATA

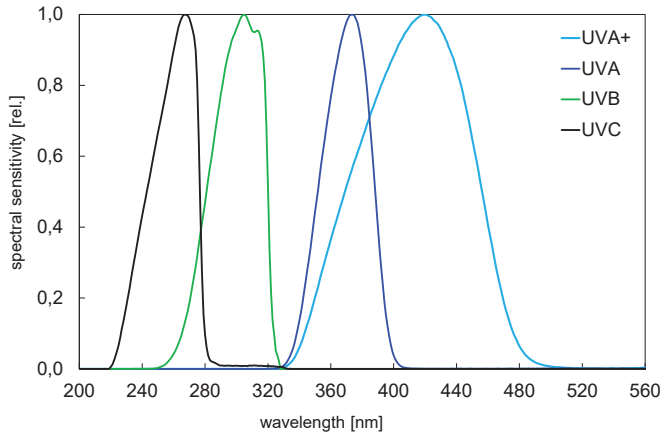

Spectral sensitivity UVA+, UVA, UVB and UVC sensors

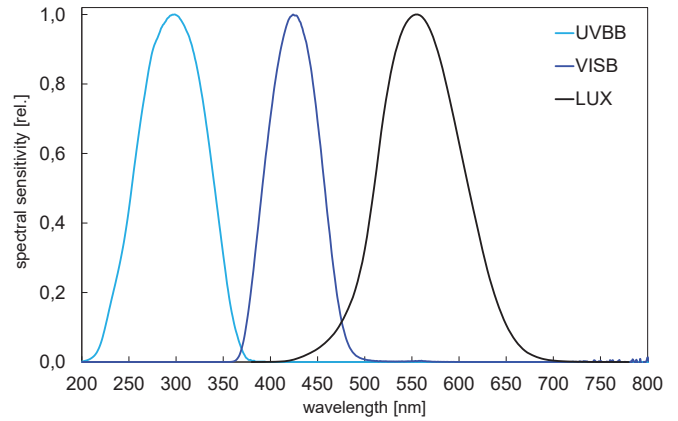

Spectral sensitivity UVBB, VISB, and VISL sensors

TECHNICAL DATA

Operation voltage	24 V (RS-485 / RS-232) 5 V (USB)
Current input	< 15 mA (RS-485 / RS-232) < 100 mA (USB)
Measuring range	0 - 10.000 mW/cm ² 0 - 10.000 µW/cm ² (optional)
Resolution	0,001 mW/cm ² 0,001 µW/cm ² (optional)
Dimensions	80 x 40 x 20 mm
Weight	150 g
Connector	Built-in plug, M8, 8-pin Phoenix Contact #1523492 SACC-DSI-M8MS-8CON-M8/0,5
I/O, RS-485 / RS-232	Trigger-In, Datarready
I/O, USB	none
Operation temperature	0 to 60 °C
Storage temperature	-10 to 60 °C
Humidity	< 80% non-condensing
Communication	115200 baud, 8 databit, 1 Stop bit, no parity RS-485: FULL-DUPLEX
Response time, typical	60 ms
Response time, max	200 ms

TYPICAL TECHNICAL DATA

Calibration uncertainty	4,5 - 7,0% (k=2)
Linearity error	< 1%
Ageing / year	< 3%

SENSOR SPECTRAL RANGES

UVC	200 - 280 nm
UVB	280 - 315 nm
UVA	315 - 400 nm
UVA+	330 - 450 nm
UVBB (Breitband)	230 - 400 nm
VISB	400 - 480 nm
LUX	380 - 780 nm, V(λ)

CONNECTOR RS-485 / RS-232

Einbausteckverbinder (in DigiPLC)
SACC-DSI-M8MS-8CON-M8/0,5 1424230

Sensor-/Aktor-Kabel
SAC-8P- 1,5-PUR/M 8FS SH 1404147

Aderbelegung

PIN	Farbe	WeiÙ	Signal VZ
1	WH	Weiß	Data Ready(O)
2	BN	Braun	+24V
3	GN	Grün	RX+ / RS485 / RX RS232
4	YE	Gelb	RX- / RS485
5	GY	Grau	TX- / RS485
6	PK	Pink	TX+ / RS485 / TX RS232
7	BU	Blau	GND
8	RD	Rot	Trigger Input (I)

OPTIONS

PLC.D MULTIPLEXER

PLC.D Multiplexer connects up to eight PLC.D sensors to a PLC. PLC communication with the PLC.D Multiplexer takes place via RS485. This switches the communication between the connected sensors. This means that only one PLC connection is required. The sensors are connected to the multiplexer via RS232 and supplied by it. The PLC.D Multiplexer is operated with 24 V DC voltage.

Example commands:

- CHx_DS_MeasResult Start of measurement for channel x
- CHx_DS_SerialNr? Query the serial number for channel x



Optional accessories: PLC.D multiplexer

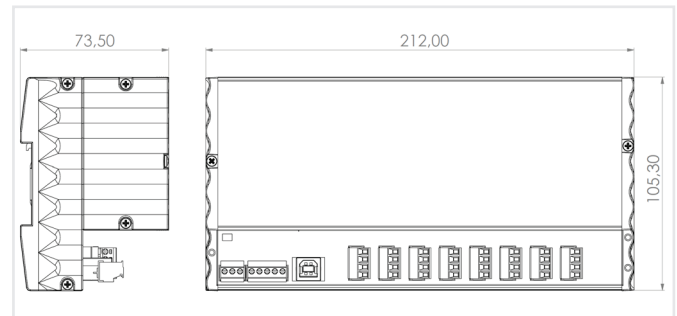

PLC.D multiplexer dimensions

TECHNICAL DATA MULTIPLEXER

Operating voltage	24 V	Sensor connections	8
Input current	< 500 mA	Sensor connection, PINs	4-pole (24 V + RS232)
PLC connection	RS485	USB	for firmware updates
Sensor connection	24 V + RS232	Dimensions	21,2 x 10,5 x 7,3 cm

OPTIONAL: SHUTTER

To protect the sensor against contamination and aging (at extremely high irradiance and periodic reference measurements) we recommend our shutter. Shutter is operated at 24 V.

TECHNICAL DATA SHUTTER

Betriebsspannung	24 V
Eingangsstrom	< 1,5 A max (pulse)
Opening time	~ 2 ms
Opening time, Delay	~ 22 ms
Closing time	~ 50 ms

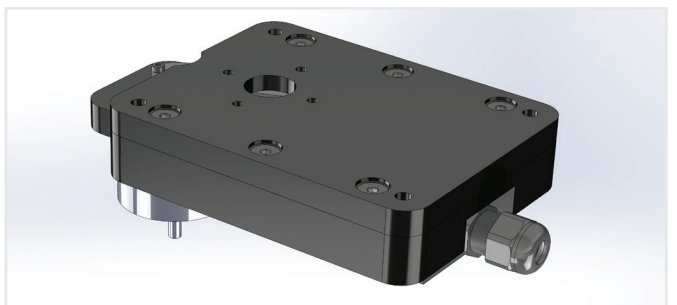

optional: shutter

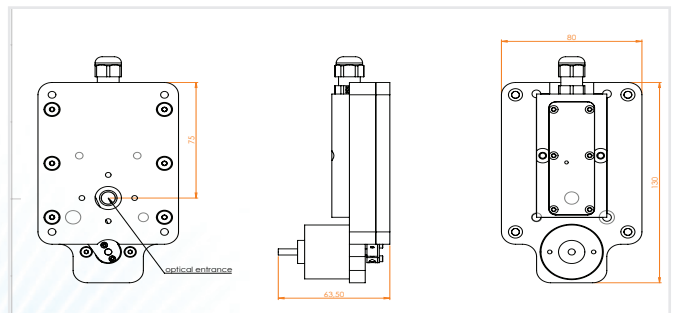

Dimensions shutter

DIMENSIONS

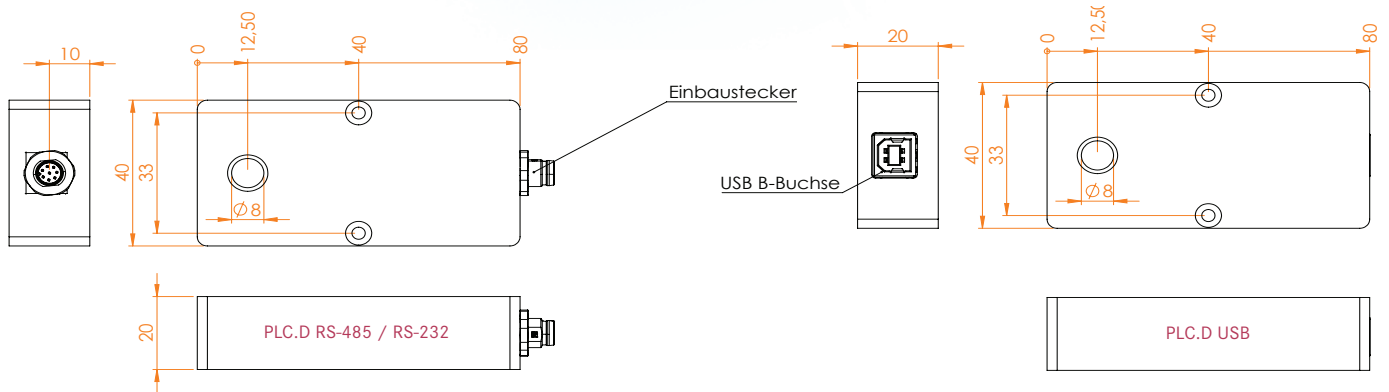

PART NUMBERS

PLC.D sensor RS-485	800 0xx
PLC.D sensor RS-232	800 1xx
PLC.D sensor USB	800 2xx
ISO 17025 calibration	17025
sensor cable, 1,5 m	920314-1.5
sensor cable, 3 m	920314-3
sensor cable, 5 m	920314-5
sensor cable, 10 m	920314-10
PLC.D Multiplexer	800008
Shutter, el. controllable	860507

SENSOR SPECTRAL RANGE CODING

UVC	xx = 10
UVB	xx = 20
UVA	xx = 32
UVA+	xx = 47
UVBB (broad-band)	xx = 12
VISB	xx = 41
LUX	xx = 61

SCOPE OF DELIVERY

PLC.D sensor, factory calibration certificate, optional ISO 17025 calibration

Please specify spectral range when ordering.

Our calibrations are available as factory and ISO 17025 calibrations and are traceable to PTB standards.

